

# ASSEMBLY INSTRUCTIONS

## Parts and Tools list

NO.	Description	Qty
1	Top support bracket	2
2	Frame End	2
3	Control Box	1
4	Center Rail	2
5	Leg	2
6	Feet	2
7	Handset	1
8	M6X10 screw	8
9	M6X14 screw	20

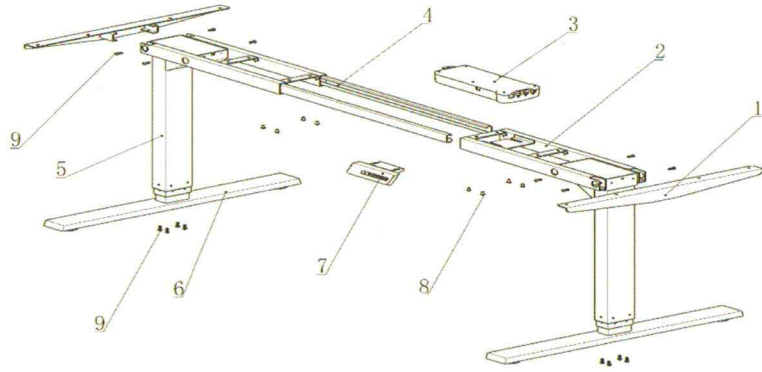

STEP 1

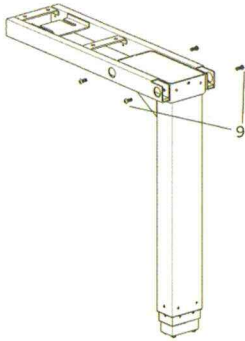

STEP 3

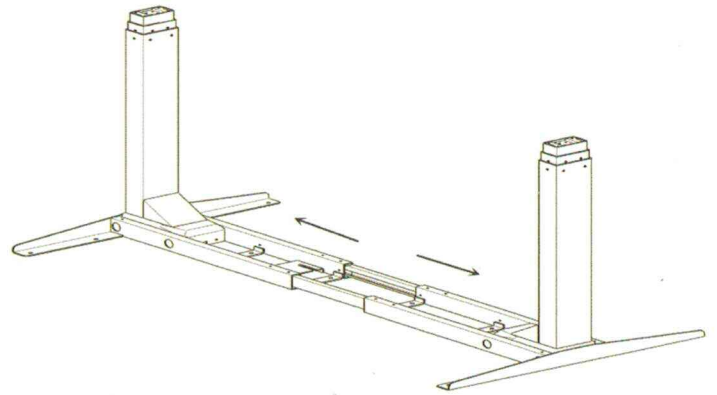

STEP 2

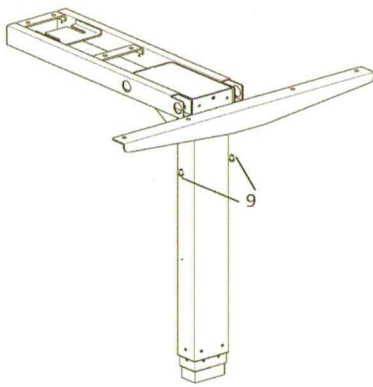

The width is determined by the desktop

STEP 4

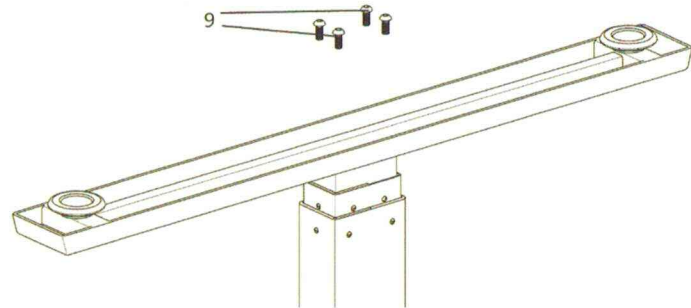

STEP 5

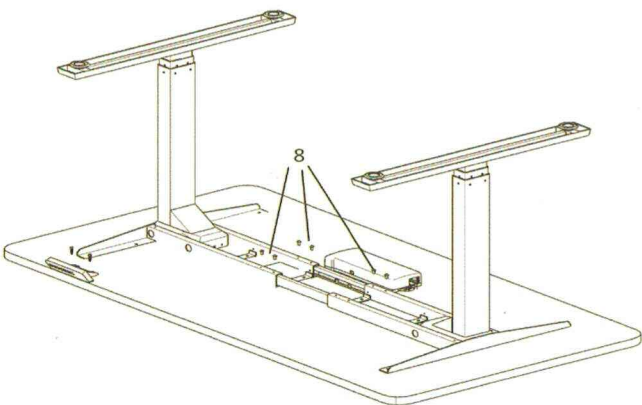

Adjust the width of the desk base to fit the desktop by sliding the two halves outward

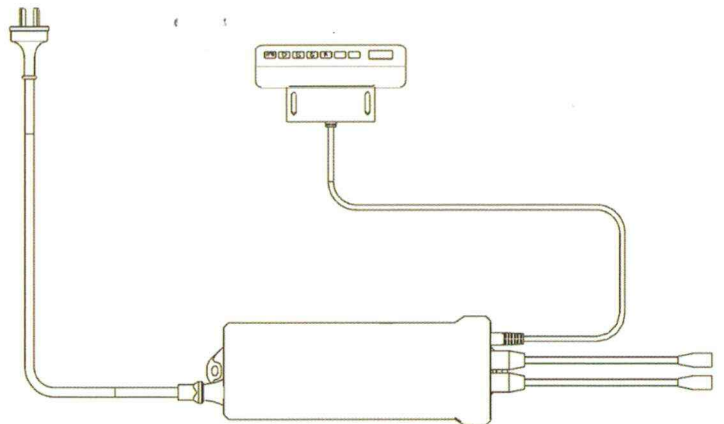

Electrical connection as shown